

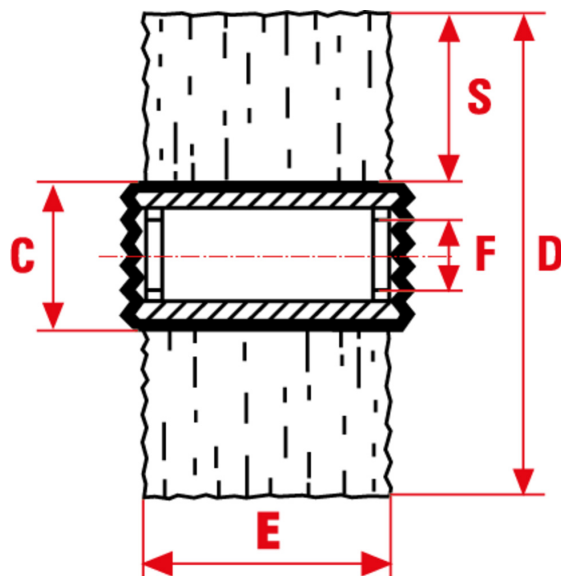

## RMD Punched-in modules brushes



Cylindrical punched-in modular brushes, standard length 100 mm, pitch 15mm, toothed on the sides, suited to form rolls of any length. RDM brushes are self-dragging thanks to the TD locking collars with three locking screws each, located at the ends of the roller.

### TYPES OF USE

Light deburring, satin finishing and polishing of any kind of surface. Abrasive nylon single-section wheel brushes are also suited for pickling and aging.

										MM					
C	D	E	S	Hole	Flap	CO/IS	ART	Black smooth nylon 0,50mm	Horsehair	Tampico Plant Fibre	white smooth nylon 0,80mm	White smooth polypropylene 0,25mm	White smooth polypropylene 0,35mm	White smooth polypropylene 0,45mm	White smooth polypropylene 0,80mm
60	100	100	20	30	17	1	RMD 100/30		1081			1080			
60	150	100	45	30	17	1	RMD 150/30	1084	1085	1086			1083		
85	180	100	47	50	20	1	RMD 180/50				2906			2905	
95	250	100	77	60	24	1	RMD 250/60		1094					1092	1093
95	200	100	52	60	24	1	RMD 200/60	1088	1090	1091	1089		1087		

Le dimensioni, le illustrazioni, le caratteristiche tecniche, le referenze e tutti gli altri dati contenuti nel catalogo possono essere modificati da SIT senza preavviso. Tutte le dimensioni riportate sul catalogo sono da considerarsi nominali e, se non diversamente specificato, sono in mm. Diametri, sporgenze e spessori degli insiemi di filamenti, costituenti le spazzole, sono da considerare tali solo approssimativamente.  
The dimensions, illustrations, technical characteristics and all other data contained in the catalogue may be changed by SIT without prior notice. All dimensions on the catalogue, unless otherwise specified, are in mm. Diameters, protrusions and thicknesses of sets of filaments forming the brushes are only approximate.

SIT Società Italiana TecnoSpazzole S.p.A

C.F. e Reg. Imprese 03492470376  
Via Porrettana, 453  
40033 - Casalecchio di Reno (Bo)  
ITALY

Partita I.V.A./VAT IT00626581201  
Codice SDI: A4707H7  
Import/Export BO 008277  
R.E.A. BO 295504

Tel. +39 0516113211  
Fax +39 051574319  
PEC: sit\_tecnoSpazzole@legalmail.it  
info@sitbrush.com

INDUSTRIAL BRUSHES MANUFACTURER WITH  
QUALITY MANAGEMENT SYSTEM CERTIFIED  
ISO 9001

sitbrush.com    

## INCH

C inch	D inch	E inch	S inch	Hole inch	Flap	CO/IS pack	ART	Black smooth nylon 0,020"	Horsehair	Tampico Plant Fibre	white smooth nylon 0,031"	White smooth polypropylene 0,010"	White smooth polypropylene 0,014"	White smooth polypropylene 0,018"	White smooth polypropylene 0,031"
2-3/8	4	4	3/4	1-1/8	17	1	RMD 100/30		1081			1080			
2-3/8	5-7/8	4	1-3/4	1-1/8	17	1	RMD 150/30	1084	1085	1086				1083	
3-3/8	7-1/8	4	1-7/8	2	20	1	RMD 180/50				2906			2905	
3-3/4	10	4	3	2-3/8	24	1	RMD 250/60		1094					1092	1093
3-3/4	8	4	2	2-3/8	24	1	RMD 200/60	1088	1090	1091	1089			1087	

Le dimensioni, le illustrazioni, le caratteristiche tecniche, le referenze e tutti gli altri dati contenuti nel catalogo possono essere modificati da SIT senza preavviso. Tutte le dimensioni riportate sul catalogo sono da considerarsi nominali e, se non diversamente specificato, sono in mm. Diametri, sporgenze e spessori degli insiemi di filamenti, costituenti le spazzole, sono da considerare tali solo approssimativamente.  
The dimensions, illustrations, technical characteristics and all other data contained in the catalogue may be changed by SIT without prior notice. All dimensions on the catalogue, unless otherwise specified, are in mm. Diameters, protrusions and thicknesses of sets of filaments forming the brushes are only approximate.

**SIT Società Italiana TecnoSpazzole S.p.A**

C.F. e Reg. Imprese 03492470376  
Via Porrettana, 453  
40033 - Casalecchio di Reno (Bo)  
ITALY

Partita I.V.A./VAT IT00626581201  
Codice SDI: A4707H7  
Import/Export BO 008277  
R.E.A. BO 295504

Tel. +39 0516113211  
Fax +39 051574319  
PEC: sit\_tecnoSpazzole@legalmail.it  
info@sitbrush.com

**INDUSTRIAL BRUSHES MANUFACTURER WITH  
QUALITY MANAGEMENT SYSTEM CERTIFIED  
ISO 9001**

**sitbrush.com**    