

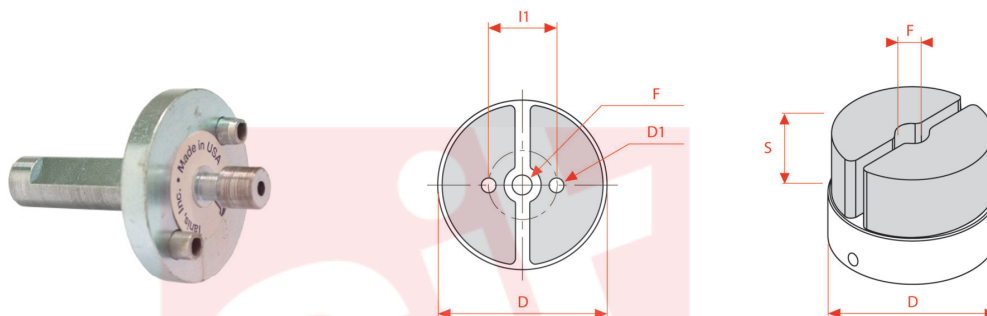

0583



Composite disc brushes are a sturdy, high-efficiency brushing tool. Greater filament density allows for more aggressive brushing and make the brush ideal for maximum productivity. Different filament patterns for applications requiring maximum density (drip pattern), or lower density (punched pattern), or with particular shape and filament configurations are available (on request). Designed for mounting on CNC machining centres or other tools and machinery.

#### TYPE OF USE

Deburring moulded parts. Deburring aerospace parts. Deburring front milled parts. Beveling grinding marks. Improving surface finishing. Deburring and finishing aluminium rims (46 grit)

Le dimensioni, le illustrazioni, le caratteristiche tecniche, le referenze e tutti gli altri dati contenuti nel catalogo possono essere modificati da SIT senza preavviso. Tutte le dimensioni riportate sul catalogo sono da considerarsi nominali e, se non diversamente specificato, sono in mm. Diametri, sporgenze e spessori degli insiemi di filamenti, costituenti le spazzole, sono da considerare tali solo approssimativamente.  
The dimensions, illustrations, technical characteristics and all other data contained in the catalogue may be changed by SIT without prior notice. All dimensions on the catalogue, unless otherwise specified, are in mm. Diameters, protrusions and thicknesses of sets of filaments forming the brushes are only approximate.

SIT Società Italiana Tecno spazzole S.p.A

C.F. e Reg. Imprese 03492470376  
Via Porrettana, 453  
40033 - Casalecchio di Reno (Bo)  
ITALY

Partita I.V.A./VAT IT00626581201  
Codice SDI: A4707H7  
Import/Export BO 008277  
R.E.A. BO 295504

Tel. +39 0516113211  
Fax +39 051574319  
PEC: sit\_tecno spazzole@legalmail.it  
info@sitbrush.com

INDUSTRIAL BRUSHES MANUFACTURER  
WITH QUALITY MANAGEMENT SYSTEM  
CERTIFIED ISO 9001

sitbrush.com    

**MM****INCH**

<b>D mm</b>	51
<b>S mm</b>	32
<b>Hole mm</b>	10
<b>Max RPM</b>	4500
<b>CO/IS pack</b>	1
<b>Art.</b>	Mini disco denso 2"
<b>Filament</b>	abrasive nylon ceramic
<b>Ø Filament</b>	1,40mm
<b>Grit</b>	

<b>D inch</b>	2
<b>S inch</b>	1-1/4
<b>Hole inch</b>	3/8
<b>Max RPM</b>	4500
<b>CO/IS pack</b>	1
<b>Art.</b>	Mini disco denso 2"
<b>Filament</b>	abrasive nylon ceramic
<b>Ø Filament</b>	0,06"
<b>Grit</b>	



sitbrush.com

Le dimensioni, le illustrazioni, le caratteristiche tecniche, le referenze e tutti gli altri dati contenuti nel catalogo possono essere modificati da SIT senza preavviso. Tutte le dimensioni riportate sul catalogo sono da considerarsi nominali e, se non diversamente specificato, sono in mm. Diametri, sporgenze e spessori degli insiemi di filamenti, costituenti le spazzole, sono da considerare tali solo approssimativamente.  
The dimensions, illustrations, technical characteristics and all other data contained in the catalogue may be changed by SIT without prior notice. All dimensions on the catalogue, unless otherwise specified, are in mm. Diameters, protrusions and thicknesses of sets of filaments forming the brushes are only approximate.

**SIT Società Italiana TecnoSpazzole S.p.A**

C.F. e Reg. Imprese 03492470376  
Via Porrettana, 453  
40033 - Casalecchio di Reno (Bo)  
ITALY

Partita I.V.A./VAT IT00626581201  
Codice SDI: A4707H7  
Import/Export BO 008277  
R.E.A. BO 295504

Tel. +39 0516113211  
Fax +39 051574319  
PEC: sit\_tecnospazzole@legalmail.it  
info@sitbrush.com

**INDUSTRIAL BRUSHES MANUFACTURER  
WITH QUALITY MANAGEMENT SYSTEM  
CERTIFIED ISO 9001**

sitbrush.com    