

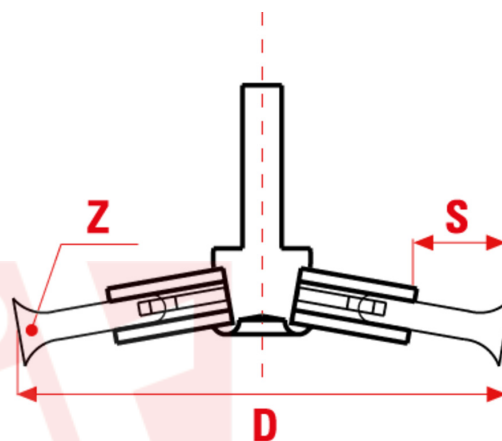

0306



**Z = n° mazzetti / number of knots
n° de mèches torsadées**

The conical shape makes them suitable for sideways jobs on irregular surfaces, with edges, profiles and cracks.

TYPE OF USE

Maintenance, removal of slags, rust and processing residues.

sitbrush.com

MM		INCH	
D mm	95	D inch	3-3/4
S mm	20	S inch	3/4
Z n°	15	Z n°	3/4
Shank mm	6X25	Shank inch	1/4X1
Max RPM	6500	Max RPM	6500
CO/IS pach	6 /48	CO/IS pack	6 /48
Art.	B CZ95 G Blister	Art.	B CZ95 G Blister
Filament	Steel	Filament	Steel
Ø Filament	0,35mm	Ø Filament	0,014"

Le dimensioni, le illustrazioni, le caratteristiche tecniche, le referenze e tutti gli altri dati contenuti nel catalogo possono essere modificati da SIT senza preavviso. Tutte le dimensioni riportate sul catalogo sono da considerarsi nominali e, se non diversamente specificato, sono in mm. Diametri, sporgenze e spessori degli insiemi di filamenti, costituenti le spazzole, sono da considerare tali solo approssimativamente.
The dimensions, illustrations, technical characteristics and all other data contained in the catalogue may be changed by SIT without prior notice. All dimensions on the catalogue, unless otherwise specified, are in mm. Diameters, protrusions and thicknesses of sets of filaments forming the brushes are only approximate.

SIT Società Italiana TecnoSpazzole S.p.A

C.F. e Reg. Imprese 03492470376
Via Porrettana, 453
40033 - Casalecchio di Reno (Bo)
ITALY

Partita I.V.A./VAT IT00626581201
Codice SDI: A4707H7
Import/Export BO 008277
R.E.A. BO 295504

Tel. +39 0516113211
Fax +39 051574319
PEC: sit_tecnoSpazzole@legalmail.it
info@sitbrush.com

**INDUSTRIAL BRUSHES MANUFACTURER
WITH QUALITY MANAGEMENT SYSTEM
CERTIFIED ISO 9001**
sitbrush.com