

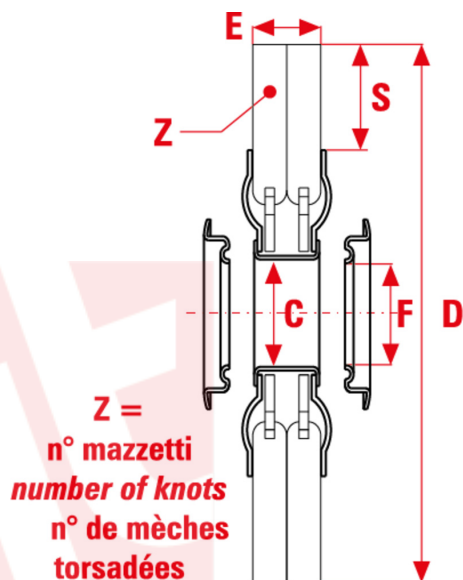

Twist knot wheel brushes



Twist knot wheel brushes suitable for heavy-duty work at high rotation speed.

TYPES OF USE

Deburring and aggressive mechanical pickling.

MM

C mm	D mm	E mm	S mm	Z n°	Hole mm	Max RPM	CO/IS pack	ART	Steel 0,50mm	Steel 0,80mm
32	150	18	30	24X2	16	9000	1/16	U3152	0511	
32	150	30	30	24X3	16	9000	1/16	U3153	0513	0514
50	200	30	43	32X2	20	9000	1/10	U5202	0524	0525
50	200	40	43	32X3	20	9000	1/9	U5203	0526	0527
77	200	30	23	40X2	25	9000	1	U8202	2198	
77	200	40	23	40X3	25	9000	1	U8203	2199	
77	250	30	48	40X2	25	4500	1	U8252	0530	0531
77	250	40	48	40X3	25	4500	1	U8253	0532	

INCH

C inch	D inch	E inch	S inch	Z n°	Hole inch	Max RPM	CO/IS pack	ART	Steel 0,020"	Steel 0,031"
1-1/4	5-7/8	3/4	1-1/8	1-1/8	5/8	9000	1/16	U3152	0511	
1-1/4	5-7/8	1-1/8	1-1/8	1-1/8	5/8	9000	1/16	U3153	0513	0514
2	8	1-1/8	1-3/4	1-3/4	3/4	9000	1/10	U5202	0524	0525
2	8	1-5/8	1-3/4	1-3/4	3/4	9000	1/9	U5203	0526	0527
3	8	1-1/8	7/8	7/8	1	9000	1	U8202	2198	

Le dimensioni, le illustrazioni, le caratteristiche tecniche, le referenze e tutti gli altri dati contenuti nel catalogo possono essere modificati da SIT senza preavviso. Tutte le dimensioni riportate sul catalogo sono da considerarsi nominali e, se non diversamente specificato, sono in mm. Diametri, sporgenze e spessori degli insiemi di filamenti, costituenti le spazzole, sono da considerare tali solo approssimativamente.
The dimensions, illustrations, technical characteristics and all other data contained in the catalogue may be changed by SIT without prior notice. All dimensions on the catalogue, unless otherwise specified, are in mm. Diameters, protrusions and thicknesses of sets of filaments forming the brushes are only approximate.

SIT Società Italiana TecnoSpazzole S.p.A

C.F. e Reg. Imprese 03492470376
Via Porrettana, 453
40033 - Casalecchio di Reno (Bo)
ITALY

Partita I.V.A./VAT IT00626581201
Codice SDI: A4707H7
Import/Export BO 008277
R.E.A. BO 295504

Tel. +39 0516113211
Fax +39 051574319
PEC: sit_tecnoSpazzole@legalmail.it
info@sitbrush.com

INDUSTRIAL BRUSHES MANUFACTURER
WITH QUALITY MANAGEMENT SYSTEM
CERTIFIED ISO 9001

sitbrush.com

C inch	D inch	E inch	S inch	Z n°	Hole inch	Max RPM	CO/IS pack	ART	Steel 0,020"	Steel 0,031"
3	8	1-5/8	7/8	7/8	1	9000	1	U8203	2199	
3	10	1-1/8	1-7/8	1-7/8	1	4500	1	U8252	0530	0531
3	10	1-5/8	1-7/8	1-7/8	1	4500	1	U8253	0532	



sitbrush.com

Le dimensioni, le illustrazioni, le caratteristiche tecniche, le referenze e tutti gli altri dati contenuti nel catalogo possono essere modificati da SIT senza preavviso. Tutte le dimensioni riportate sul catalogo sono da considerarsi nominali e, se non diversamente specificato, sono in mm. Diametri, sporgenze e spessori degli insiemi di filamenti, costituenti le spazzole, sono da considerare tali solo approssimativamente.
The dimensions, illustrations, technical characteristics and all other data contained in the catalogue may be changed by SIT without prior notice. All dimensions on the catalogue, unless otherwise specified, are in mm. Diameters, protrusions and thicknesses of sets of filaments forming the brushes are only approximate.

SIT Società Italiana Tecno-spazzole S.p.A

C.F. e Reg. Imprese 03492470376
Via Porrettana, 453
40033 - Casalecchio di Reno (Bo)
ITALY

Partita I.V.A./VAT IT00626581201
Codice SDI: A4707H7
Import/Export BO 008277
R.E.A. BO 295504

Tel. +39 0516113211
Fax +39 051574319
PEC: sit_tecno-spazzole@legalmail.it
info@sitbrush.com

**INDUSTRIAL BRUSHES MANUFACTURER
WITH QUALITY MANAGEMENT SYSTEM
CERTIFIED ISO 9001**

sitbrush.com    