

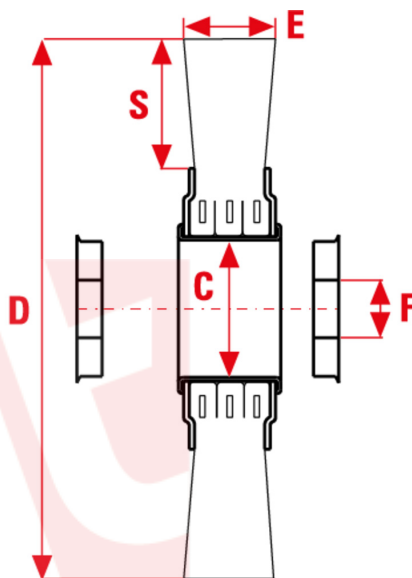

## 10-12000 series wheel brushes



Crimped steel wire wheel brushes. The new 10-12000 series comes with higher wire density, shorter trim length and flanges with a thicker diameter. These features ensure increased aggressiveness and a longer lifetime.

### TYPES OF USE

Deburring, satin finishing and polishing of surfaces of any shape and material.

sitbrush.com

### MM

C	D	E	S	Hole	Max RPM	CO/IS	ART	Stainless Steel	Steel	Steel
mm	mm	mm	mm	mm		pack		0,30mm	0,35mm	0,50mm
100	250	55	35	100	3600	1	10255		9210	
100	250	55	35	80	3600	1	10255		0095	
100	300	35	60	30	3000	1	10302	0924	0086	0087
100	300	42	60	30	3000	1	10303		0089	
100	300	56	60	100	3000	1	10305		9235	
100	300	56	60	2"+2ch	3000	1	10305		9234	
120	350	50	85	30	2400	1	12354		9258	9259

### INCH

C	D	E	S	Hole	Max RPM	CO/IS	ART	Stainless Steel	Steel	Steel
inch	inch	inch	inch	inch		pack		0,012"	0,014"	0,020"
4	10	2-1/8	1-3/8	4	3600	1	10255		9210	
4	10	2-1/8	1-3/8	3-1/8	3600	1	10255		0095	
4	12	1	2-3/8	1-1/8	3000	1	10302	0924	0086	0087

Le dimensioni, le illustrazioni, le caratteristiche tecniche, le referenze e tutti gli altri dati contenuti nel catalogo possono essere modificati da SIT senza preavviso. Tutte le dimensioni riportate sul catalogo sono da considerarsi nominali e, se non diversamente specificato, sono in mm. Diametri, sporgenze e spessori degli insiemi di filamenti, costituenti le spazzole, sono da considerare tali solo approssimativamente.  
The dimensions, illustrations, technical characteristics and all other data contained in the catalogue may be changed by SIT without prior notice. All dimensions on the catalogue, unless otherwise specified, are in mm. Diameters, protrusions and thicknesses of sets of filaments forming the brushes are only approximate.

SIT Società Italiana TecnoSpazzole S.p.A

C.F. e Reg. Imprese 03492470376  
Via Porrettana, 453  
40033 - Casalecchio di Reno (Bo)  
ITALY

Partita I.V.A./VAT IT00626581201  
Codice SDI: A4707H7  
Import/Export BO 008277  
R.E.A. BO 295504

Tel. +39 0516113211  
Fax +39 051574319  
PEC: sit\_tecnoSpazzole@legalmail.it  
info@sitbrush.com

INDUSTRIAL BRUSHES MANUFACTURER  
WITH QUALITY MANAGEMENT SYSTEM  
CERTIFIED ISO 9001

sitbrush.com

C inch	D inch	E inch	S inch	Hole inch	Max RPM	CO/IS pack	ART	Stainless Steel 0,012"	Steel 0,014"	Steel 0,020"
4	12	1-5/8	2-3/8	1-1/8	3000	1	10303		0089	
4	12	2-3/16	2-3/8	4	3000	1	10305		9235	
4	12	2-3/16	2-3/8	2+2ch	3000	1	10305		9234	
4-3/4	13-3/4	2	3-3/8	1-1/8	2400	1	12354		9258	9259



sitbrush.com

Le dimensioni, le illustrazioni, le caratteristiche tecniche, le referenze e tutti gli altri dati contenuti nel catalogo possono essere modificati da SIT senza preavviso. Tutte le dimensioni riportate sul catalogo sono da considerarsi nominali e, se non diversamente specificato, sono in mm. Diametri, sporgenze e spessori degli insiemi di filamenti, costituenti le spazzole, sono da considerare tali solo approssimativamente.  
The dimensions, illustrations, technical characteristics and all other data contained in the catalogue may be changed by SIT without prior notice. All dimensions on the catalogue, unless otherwise specified, are in mm. Diameters, protrusions and thicknesses of sets of filaments forming the brushes are only approximate.

**SIT Società Italiana Tecno-spazzole S.p.A**

C.F. e Reg. Imprese 03492470376  
Via Porrettana, 453  
40033 - Casalecchio di Reno (Bo)  
ITALY

Partita I.V.A./VAT IT00626581201  
Codice SDI: A4707H7  
Import/Export BO 008277  
R.E.A. BO 295504

Tel. +39 0516113211  
Fax +39 051574319  
PEC: sit\_tecno-spazzole@legalmail.it  
info@sitbrush.com

**INDUSTRIAL BRUSHES MANUFACTURER  
WITH QUALITY MANAGEMENT SYSTEM  
CERTIFIED ISO 9001**

**sitbrush.com**    