

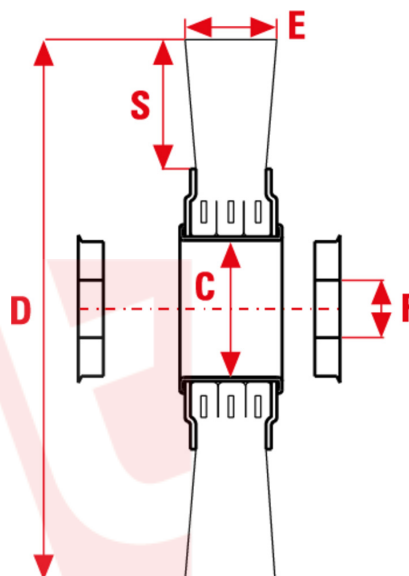

0709



Crimped brass-coated steel wire wheel brushes. The CE series includes lighter brushes, with lower wire density.

### TYPE OF USE

Deburring, satin finishing and polishing of surfaces of any shape and material. Compared to the Tech line, they are suitable for lighter and less continuous work.

sitbrush.com

	MM
<b>C mm</b>	28
<b>D mm</b>	125
<b>E mm</b>	20
<b>S mm</b>	32
<b>Hole mm</b>	16
<b>Max RPM</b>	6000
<b>CO/IS pach</b>	5 /40
<b>Art.</b>	CE3122
<b>Filament</b>	Brass Coated Steel
<b>Ø Filament</b>	0,30mm

	INCH
<b>C inch</b>	1-1/8
<b>D inch</b>	5
<b>E inch</b>	3/4
<b>S inch</b>	1-1/4
<b>Hole inch</b>	5/8
<b>Max RPM</b>	6000
<b>CO/IS pack</b>	5 /40
<b>Art.</b>	CE3122
<b>Filament</b>	Brass Coated Steel
<b>Ø Filament</b>	0,012"

Le dimensioni, le illustrazioni, le caratteristiche tecniche, le referenze e tutti gli altri dati contenuti nel catalogo possono essere modificati da SIT senza preavviso. Tutte le dimensioni riportate sul catalogo sono da considerarsi nominali e, se non diversamente specificato, sono in mm. Diametri, sporgenze e spessori degli insiemi di filamenti, costituenti le spazzole, sono da considerare tali solo approssimativamente.  
The dimensions, illustrations, technical characteristics and all other data contained in the catalogue may be changed by SIT without prior notice. All dimensions on the catalogue, unless otherwise specified, are in mm. Diameters, protrusions and thicknesses of sets of filaments forming the brushes are only approximate.

SIT Società Italiana TecnoSpazzole S.p.A

C.F. e Reg. Imprese 03492470376  
Via Porrettana, 453  
40033 - Casalecchio di Reno (Bo)  
ITALY

Partita I.V.A./VAT IT00626581201  
Codice SDI: A4707H7  
Import/Export BO 008277  
R.E.A. BO 295504

Tel. +39 0516113211  
Fax +39 051574319  
PEC: sit\_tecnospazzole@legalmail.it  
info@sitbrush.com

INDUSTRIAL BRUSHES MANUFACTURER  
WITH QUALITY MANAGEMENT SYSTEM  
CERTIFIED ISO 9001

sitbrush.com