

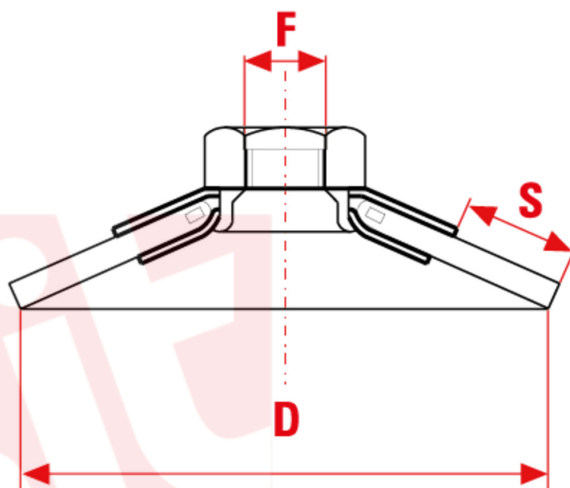

CO Bevel brushes



The conical shape makes these brushes suitable for sideways jobs on irregular surfaces, with edges, profiles and cracks. Made of high resistance crimped wire.

TYPES OF USE

To remove slags, rust and residues from surfaces of any shape and material.

MM

D mm	S mm	Hole mm	Max RPM	CO/IS pack	ART	LIZ stainless steel cord 0,35mm	Stainless Steel 0,30mm	Steel 0,35mm
90	20	M14	14000	6 /48	B CO90 Blister		0945	
90	20	M14+5/8"	14000	1 /36	CO90		0958	0171
90	20	M14	14000	12 /96	CO90			0173
90	20	M14	14000	1 /36	CO90	0178	0946	0172
120	22	M14	12500	1 /32	CO120		2430	0175
150	25	M14	9000	1 /16	CO150		2433	0176

INCH

D inch	S inch	Hole inch	Max RPM	CO/IS pack	ART	LIZ stainless steel cord 0,014"	Stainless Steel 0,012"	Steel 0,014"
3-1/2	3/4	M14	14000	6 /48	B CO90 Blister		0945	
3-1/2	3/4	M14+5/8	14000	1 /36	CO90		0958	0171
3-1/2	3/4	M14	14000	12 /96	CO90			0173
3-1/2	3/4	M14	14000	1 /36	CO90	0178	0946	0172
4-3/4	7/8	M14	12500	1 /32	CO120		2430	0175

Le dimensioni, le illustrazioni, le caratteristiche tecniche, le referenze e tutti gli altri dati contenuti nel catalogo possono essere modificati da SIT senza preavviso. Tutte le dimensioni riportate sul catalogo sono da considerarsi nominali e, se non diversamente specificato, sono in mm. Diametri, sporgenze e spessori degli insiemi di filamenti, costituenti le spazzole, sono da considerare tali solo approssimativamente.
The dimensions, illustrations, technical characteristics and all other data contained in the catalogue may be changed by SIT without prior notice. All dimensions on the catalogue, unless otherwise specified, are in mm. Diameters, protrusions and thicknesses of sets of filaments forming the brushes are only approximate.

SIT Società Italiana TecnoSpazzole S.p.A

C.F. e Reg. Imprese 03492470376
Via Porrettana, 453
40033 - Casalecchio di Reno (Bo)
ITALY

Partita I.V.A./VAT IT00626581201
Codice SDI: A4707H7
Import/Export BO 008277
R.E.A. BO 295504

Tel. +39 0516113211
Fax +39 051574319
PEC: sit_tecnospazzole@legalmail.it
info@sitbrush.com

INDUSTRIAL BRUSHES MANUFACTURER
WITH QUALITY MANAGEMENT SYSTEM
CERTIFIED ISO 9001

sitbrush.com

D inch	S inch	Hole inch	Max RPM	CO/IS pack	ART	LIZ stainless steel cord 0,014"	Stainless Steel 0,012"	Steel 0,014"
5-7/8	1	M14	9000	1 /16	CO150		2433	0176



sitbrush.com

Le dimensioni, le illustrazioni, le caratteristiche tecniche, le referenze e tutti gli altri dati contenuti nel catalogo possono essere modificati da SIT senza preavviso. Tutte le dimensioni riportate sul catalogo sono da considerarsi nominali e, se non diversamente specificato, sono in mm. Diametri, sporgenze e spessori degli insiemi di filamenti, costituenti le spazzole, sono da considerare tali solo approssimativamente.
The dimensions, illustrations, technical characteristics and all other data contained in the catalogue may be changed by SIT without prior notice. All dimensions on the catalogue, unless otherwise specified, are in mm. Diameters, protrusions and thicknesses of sets of filaments forming the brushes are only approximate.

SIT Società Italiana TecnoSpazzole S.p.A

C.F. e Reg. Imprese 03492470376
Via Porrettana, 453
40033 - Casalecchio di Reno (Bo)
ITALY

Partita I.V.A./VAT IT00626581201
Codice SDI: A4707H7
Import/Export BO 008277
R.E.A. BO 295504

Tel. +39 0516113211
Fax +39 051574319
PEC: sit_tecnospazzole@legalmail.it
info@sitbrush.com

**INDUSTRIAL BRUSHES MANUFACTURER
WITH QUALITY MANAGEMENT SYSTEM
CERTIFIED ISO 9001**

sitbrush.com    