

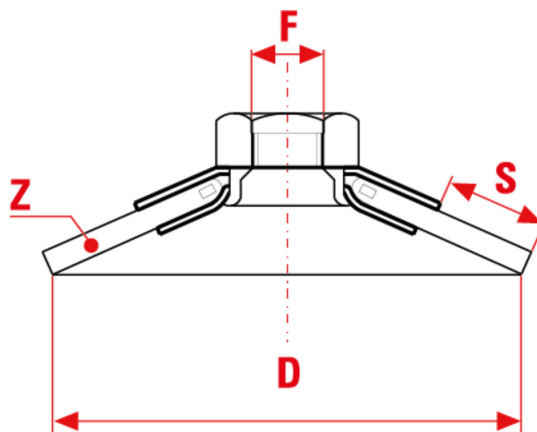

Brosses coniques CZ



**Z = n° mazzetti / number of knots
n° de mèches torsadées**

La forme conica rend ces brosses aptes aux travaux “de coupe” sur des surfaces irrégulières, avec des bords, profils et fissures. Les mèches torsadées en font une brosse agressive.

APLICATIONS

Élimination d'encrassements, rouille et résidus des surfaces de tout matériau et forme.

MM

D mm	S mm	Z n°	Trou mm	Max RPM	CO/IS pack	ART	Acier 0,50mm	Inox 0,50mm
95	20	18	M10	14000	6 /48	B CZ95 Blister	0761	0949
95	20	18	M14	14000	6 /48	B CZ95 Blister	0760	0950
95	20	18	M10	14000	1 /36	CZ95	0312	
95	20	18	M14+5/8"	14000	1 /36	CZ95	2562	0948
95	20	18	M14	14000	12 /48	CZ95	0309	
95	20	18	M14	14000	1 /36	CZ95	0308	0951
100	17	24	M14	12500	1 /32	CZ100	0351	
115	25	24	M14	12500	1 /32	CZ115	0352	
125	25	24	M14	9000	1 /32	CZ125	0315	2465
150	25	24	M14	9000	1 /16	CZ150	0316	2464

INCH

Le dimensioni, le illustrazioni, le caratteristiche tecniche, le referenze e tutti gli altri dati contenuti nel catalogo possono essere modificati da SIT senza preavviso. Tutte le dimensioni riportate sul catalogo sono da considerarsi nominali e, se non diversamente specificato, sono in mm. Diametri, sporgenze e spessori degli insiemi di filamenti, costituenti le spazzole, sono da considerare tali solo approssimativamente.
The dimensions, illustrations, technical characteristics and all other data contained in the catalogue may be changed by SIT without prior notice. All dimensions on the catalogue, unless otherwise specified, are in mm. Diameters, protrusions and thicknesses of sets of filaments forming the brushes are only approximate.

SIT Società Italiana TecnoSpazzole S.p.A

C.F. e Reg. Imprese 03492470376
Via Porrettana, 453
40033 - Casalecchio di Reno (Bo)
ITALY

Partita I.V.A./VAT IT00626581201
Codice SDI: A4707H7
Import/Export BO 008277
R.E.A. BO 295504

Tel. +39 0516113211
Fax +39 051574319
PEC: sit_tecnoSpazzole@legalmail.it
info@sitbrush.com

INDUSTRIAL BRUSHES MANUFACTURER WITH
QUALITY MANAGEMENT SYSTEM CERTIFIED
ISO 9001

sitbrush.com    

D inch	S inch	Z n°	Trou inch	Max RPM	CO/IS pack	ART	Acier 0,020"	Inox 0,020"
3-3/4	3/4	3/4	M10	14000	6 /48	B CZ95 Blister	0761	0949
3-3/4	3/4	3/4	M14	14000	6 /48	B CZ95 Blister	0760	0950
3-3/4	3/4	3/4	M10	14000	1 /36	CZ95	0312	
3-3/4	3/4	3/4	M14+5/8	14000	1 /36	CZ95	2562	0948
3-3/4	3/4	3/4	M14	14000	12 /48	CZ95	0309	
3-3/4	3/4	3/4	M14	14000	1 /36	CZ95	0308	0951
4	5/8	5/8	M14	12500	1 /32	CZ100	0351	
4-1/2	1	1	M14	12500	1 /32	CZ115	0352	
5	1	1	M14	9000	1 /32	CZ125	0315	2465
5-7/8	1	1	M14	9000	1 /16	CZ150	0316	2464

Le dimensioni, le illustrazioni, le caratteristiche tecniche, le referenze e tutti gli altri dati contenuti nel catalogo possono essere modificati da SIT senza preavviso. Tutte le dimensioni riportate sul catalogo sono da considerarsi nominali e, se non diversamente specificato, sono in mm. Diametri, sporgenze e spessori degli insiemi di filamenti, costituenti le spazzole, sono da considerare tali solo approssimativamente.
The dimensions, illustrations, technical characteristics and all other data contained in the catalogue may be changed by SIT without prior notice. All dimensions on the catalogue, unless otherwise specified, are in mm. Diameters, protrusions and thicknesses of sets of filaments forming the brushes are only approximate.

SIT Società Italiana TecnoSpazzole S.p.A

C.F. e Reg. Imprese 03492470376
Via Porrettana, 453
40033 - Casalecchio di Reno (Bo)
ITALY

Partita I.V.A./VAT IT00626581201
Codice SDI: A4707H7
Import/Export BO 008277
R.E.A. BO 295504

Tel. +39 0516113211
Fax +39 051574319
PEC: sit_tecnoSpazzole@legalmail.it
info@sitbrush.com

INDUSTRIAL BRUSHES MANUFACTURER WITH
QUALITY MANAGEMENT SYSTEM CERTIFIED
ISO 9001

sitbrush.com    