

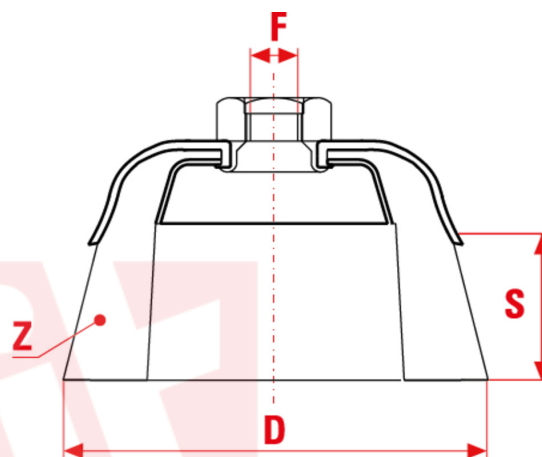

6000



**Z = n° mazzetti / number of knots
n° de mèches torsadées**

“X-LOCK est le système innovant pour le remplacement d’accessoires breveté par Bosch. Il permet de brancher et débrancher les brosses des meuleuses d’angle compatibles jusqu’à 5 fois plus rapidement et en toute sécurité.

APPLICATION

Légers ébavurages, finitions satinées, nettoyage de petites scories et de la rouille, bavures de têtes de tuyaux.

sitbrush.com

	MM		INCH
D mm	75	D inch	3
S mm	20	S inch	3/4
Z n°	18	Z n°	3/4
Trou mm	X-LOCK	Trou inch	X-LOCK
Max RPM	12500	Max RPM	12500
CO/IS pach	1 /18	CO/IS pack	1 /18
Art.	TZ70 XLK	Art.	TZ70 XLK
Filo	Acier	Filo	Acier
Ø Filo	0,50mm	Ø Filo	0,020"

Le dimensioni, le illustrazioni, le caratteristiche tecniche, le referenze e tutti gli altri dati contenuti nel catalogo possono essere modificati da SIT senza preavviso. Tutte le dimensioni riportate sul catalogo sono da considerarsi nominali e, se non diversamente specificato, sono in mm. Diametri, sporgenze e spessori degli insiemi di filamenti, costituenti le spazzole, sono da considerare tali solo approssimativamente.
The dimensions, illustrations, technical characteristics and all other data contained in the catalogue may be changed by SIT without prior notice. All dimensions on the catalogue, unless otherwise specified, are in mm. Diameters, protrusions and thicknesses of sets of filaments forming the brushes are only approximate.

SIT Società Italiana TecnoSpazzole S.p.A

C.F. e Reg. Imprese 03492470376
Via Porrettana, 453
40033 - Casalecchio di Reno (Bo)
ITALY

Partita I.V.A./VAT IT00626581201
Codice SDI: A4707H7
Import/Export BO 008277
R.E.A. BO 295504

Tel. +39 0516113211
Fax +39 051574319
PEC: sit_tecnoSpazzole@legalmail.it
info@sitbrush.com

INDUSTRIAL BRUSHES MANUFACTURER
WITH QUALITY MANAGEMENT SYSTEM
CERTIFIED ISO 9001

sitbrush.com