

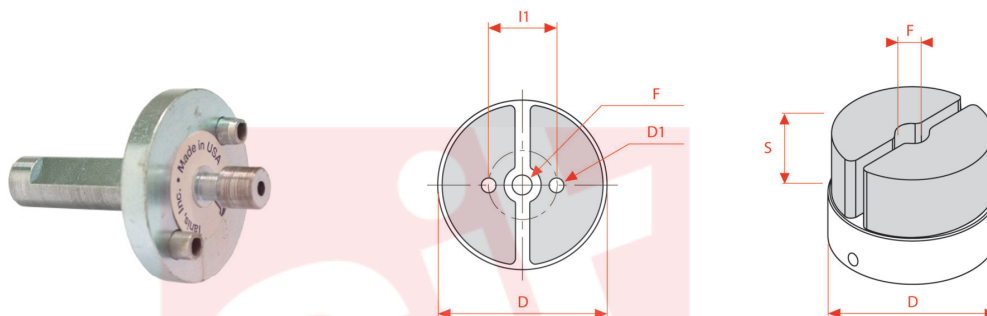

0584



Les brosses en composite à disque constituent un outil de brossage robuste et à grande efficacité. Des plus grandes densités de filaments permettent un brossage plus agressif et rendent la brosse idéale pour la maximale productivité. Il existe des différents modèles de filament pour des applications qui nécessitent une densité maximale (modèle à goutte) ou une mineure densité (modèle poinçonné) ou avec des configurations particulières de forme et filament (sur demande). Conçues pour le montage sur des centres d'usinage CNC ou d'autres outils et machines.

APLICACION

Ébavurer des composants moulés. Ébavurer des composants du secteur aéronautique. Ébavurer des composants fraisés frontalement. Chanfreiner les signes de meulage. Améliorer la finition superficielle. Ébavurer et finir les jantes en aluminium (grain 46).

Le dimensioni, le illustrazioni, le caratteristiche tecniche, le referenze e tutti gli altri dati contenuti nel catalogo possono essere modificati da SIT senza preavviso. Tutte le dimensioni riportate sul catalogo sono da considerarsi nominali e, se non diversamente specificato, sono in mm. Diametri, sporgenze e spessori degli insiemi di filamenti, costituenti le spazzole, sono da considerare tali solo approssimativamente.
The dimensions, illustrations, technical characteristics and all other data contained in the catalogue may be changed by SIT without prior notice. All dimensions on the catalogue, unless otherwise specified, are in mm. Diameters, protrusions and thicknesses of sets of filaments forming the brushes are only approximate.

SIT Società Italiana Tecnoazzole S.p.A

C.F. e Reg. Imprese 03492470376
Via Porrettana, 453
40033 - Casalecchio di Reno (Bo)
ITALY

Partita I.V.A./VAT IT00626581201
Codice SDI: A4707H7
Import/Export BO 008277
R.E.A. BO 295504

Tel. +39 0516113211
Fax +39 051574319
PEC: sit_tecnoazzole@legalmail.it
info@sitbrush.com

INDUSTRIAL BRUSHES MANUFACTURER
WITH QUALITY MANAGEMENT SYSTEM
CERTIFIED ISO 9001

sitbrush.com    

MM**INCH**

D mm	76
S mm	32
Trou mm	10
Max RPM	4500
CO/IS pack	1
Art.	Mini disco denso 3"
Filo	Nylon abrasif céramique
Ø Filo	1,00mm
Grit	

D inch	3
S inch	1-1/4
Trou inch	3/8
Max RPM	4500
CO/IS pack	1
Art.	Mini disco denso 3"
Filo	Nylon abrasif céramique
Ø Filo	0,04"
Grit	



sitbrush.com

Le dimensioni, le illustrazioni, le caratteristiche tecniche, le referenze e tutti gli altri dati contenuti nel catalogo possono essere modificati da SIT senza preavviso. Tutte le dimensioni riportate sul catalogo sono da considerarsi nominali e, se non diversamente specificato, sono in mm. Diametri, sporgenze e spessori degli insiemi di filamenti, costituenti le spazzole, sono da considerare tali solo approssimativamente.
The dimensions, illustrations, technical characteristics and all other data contained in the catalogue may be changed by SIT without prior notice. All dimensions on the catalogue, unless otherwise specified, are in mm. Diameters, protrusions and thicknesses of sets of filaments forming the brushes are only approximate.

SIT Società Italiana Tecno spazzole S.p.A

C.F. e Reg. Imprese 03492470376
Via Porrettana, 453
40033 - Casalecchio di Reno (Bo)
ITALY

Partita I.V.A./VAT IT00626581201
Codice SDI: A4707H7
Import/Export BO 008277
R.E.A. BO 295504

Tel. +39 0516113211
Fax +39 051574319
PEC: sit_tecnospazzole@legalmail.it
info@sitbrush.com

**INDUSTRIAL BRUSHES MANUFACTURER
WITH QUALITY MANAGEMENT SYSTEM
CERTIFIED ISO 9001**

sitbrush.com    