

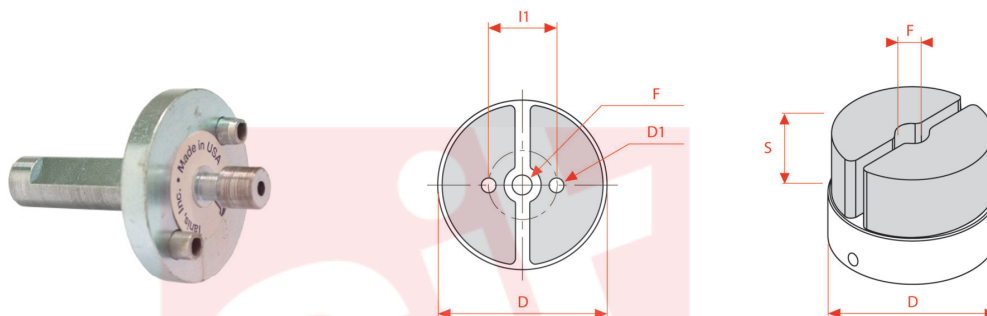

0583



Los cepillos compuestos de disco constituyen una herramienta de cepillado robusta y de alta eficiencia. Las mayores densidades de filamento permiten un cepillado más agresivo y hacen que el cepillo sea ideal para obtener la máxima productividad. Están disponibles diversos diseños de filamento para aplicaciones que requieren la máxima densidad (diseño en forma de gota) o menor densidad (diseño insertado) o con configuraciones especiales. Diseñados para el montaje en centros de trabajo de control numérico o en otras herramientas y maquinarias.

APLICACION

Desbarbar componentes moldeados. Desbarbar componentes del sector aeronáutico. Desbarbar componentes fresados frontalmente. Redondear marcas de rectificado. Mejorar el acabado de la superficie. Desbarbar y acabar llantas de aluminio (grano 46).

Le dimensioni, le illustrazioni, le caratteristiche tecniche, le referenze e tutti gli altri dati contenuti nel catalogo possono essere modificati da SIT senza preavviso. Tutte le dimensioni riportate sul catalogo sono da considerarsi nominali e, se non diversamente specificato, sono in mm. Diametri, sporgenze e spessori degli insiemi di filamenti, costituenti le spazzole, sono da considerare tali solo approssimativamente.
The dimensions, illustrations, technical characteristics and all other data contained in the catalogue may be changed by SIT without prior notice. All dimensions on the catalogue, unless otherwise specified, are in mm. Diameters, protrusions and thicknesses of sets of filaments forming the brushes are only approximate.

SIT Società Italiana Tecno-spazzole S.p.A

C.F. e Reg. Imprese 03492470376
Via Porrettana, 453
40033 - Casalecchio di Reno (Bo)
ITALY

Partita I.V.A./VAT IT00626581201
Codice SDI: A4707H7
Import/Export BO 008277
R.E.A. BO 295504

Tel. +39 0516113211
Fax +39 051574319
PEC: sit_tecno-spazzole@legalmail.it
info@sitbrush.com

INDUSTRIAL BRUSHES MANUFACTURER
WITH QUALITY MANAGEMENT SYSTEM
CERTIFIED ISO 9001

sitbrush.com

MM**INCH**

D mm	51
S mm	32
Foro mm	10
Max RPM	4500
CO/IS pack	1
Art.	Mini disco denso 2"
Hilo	Nailon abrasivo cerámico
Ø Hilo	1,40mm
Grit	

D inch	2
S inch	1-1/4
Foro inch	3/8
Max RPM	4500
CO/IS pack	1
Art.	Mini disco denso 2"
Hilo	Nailon abrasivo cerámico
Ø Hilo	0,06"
Grit	



sitbrush.com

Le dimensioni, le illustrazioni, le caratteristiche tecniche, le referenze e tutti gli altri dati contenuti nel catalogo possono essere modificati da SIT senza preavviso. Tutte le dimensioni riportate sul catalogo sono da considerarsi nominali e, se non diversamente specificato, sono in mm. Diametri, sporgenze e spessori degli insiemi di filamenti, costituenti le spazzole, sono da considerare tali solo approssimativamente.
The dimensions, illustrations, technical characteristics and all other data contained in the catalogue may be changed by SIT without prior notice. All dimensions on the catalogue, unless otherwise specified, are in mm. Diameters, protrusions and thicknesses of sets of filaments forming the brushes are only approximate.

SIT Società Italiana TecnoSpazzole S.p.A

C.F. e Reg. Imprese 03492470376
Via Porrettana, 453
40033 - Casalecchio di Reno (Bo)
ITALY

Partita I.V.A./VAT IT00626581201
Codice SDI: A4707H7
Import/Export BO 008277
R.E.A. BO 295504

Tel. +39 0516113211
Fax +39 051574319
PEC: sit_tecnospazzole@legalmail.it
info@sitbrush.com

**INDUSTRIAL BRUSHES MANUFACTURER
WITH QUALITY MANAGEMENT SYSTEM
CERTIFIED ISO 9001**

sitbrush.com    