

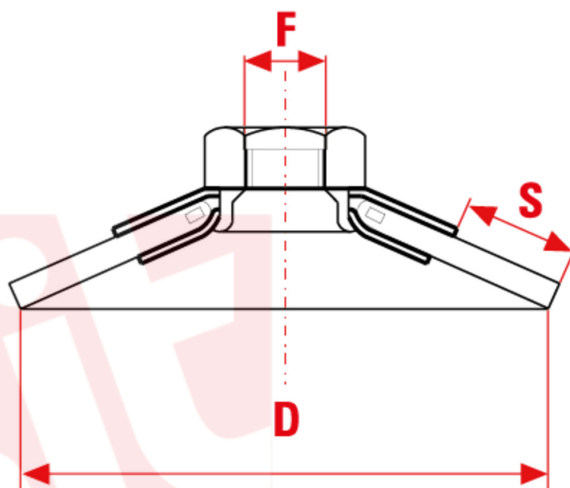

Konische Bürsten CO



Durch die konische Form sind diese Bürsten für Arbeiten „zum Schneiden“ an unregelmäßigen Oberflächen mit Kanten, Profilen und Schlitzern geeignet. Aus gekräuseltem, sehr widerstandsfähigem Stahl.

NUTZUNGSARTEN

Beseitigung von Rückständen, Rost und Ablagerungen von Oberflächen aus beliebigem Material und mit beliebiger Form.

sitbrush.com

MM

D mm	S mm	Loch mm	Max RPM	CO/IS pack	ART	Edelstahlitzendraht 0,35mm	Rostfrei 0,30mm	Stahl 0,35mm
90	20	M14	14000	6 /48	B CO90 Blister		0945	
90	20	M14+5/8"	14000	1 /36	CO90		0958	0171
90	20	M14	14000	12 /96	CO90			0173
90	20	M14	14000	1 /36	CO90	0178	0946	0172
120	22	M14	12500	1 /32	CO120		2430	0175
150	25	M14	9000	1 /16	CO150		2433	0176

INCH

D inch	S inch	Loch inch	Max RPM	CO/IS pack	ART	Edelstahlitzendraht 0,014"	Rostfrei 0,012"	Stahl 0,014"
3-1/2	3/4	M14	14000	6 /48	B CO90 Blister		0945	
3-1/2	3/4	M14+5/8	14000	1 /36	CO90		0958	0171
3-1/2	3/4	M14	14000	12 /96	CO90			0173

Le dimensioni, le illustrazioni, le caratteristiche tecniche, le referenze e tutti gli altri dati contenuti nel catalogo possono essere modificati da SIT senza preavviso. Tutte le dimensioni riportate sul catalogo sono da considerarsi nominali e, se non diversamente specificato, sono in mm. Diametri, sporgenze e spessori degli insiemi di filamenti, costituenti le spazzole, sono da considerare tali solo approssimativamente.
The dimensions, illustrations, technical characteristics and all other data contained in the catalogue may be changed by SIT without prior notice. All dimensions on the catalogue, unless otherwise specified, are in mm. Diameters, protrusions and thicknesses of sets of filaments forming the brushes are only approximate.

SIT Società Italiana Tecnoazzole S.p.A

C.F. e Reg. Imprese 03492470376
Via Porrettana, 453
40033 - Casalecchio di Reno (Bo)
ITALY

Partita I.V.A./VAT IT00626581201
Codice SDI: A4707H7
Import/Export BO 008277
R.E.A. BO 295504

Tel. +39 0516113211
Fax +39 051574319
PEC: sit_tecnoazzole@legalmail.it
info@sitbrush.com

INDUSTRIAL BRUSHES MANUFACTURER
WITH QUALITY MANAGEMENT SYSTEM
CERTIFIED ISO 9001

sitbrush.com

D inch	S inch	Loch inch	Max RPM	CO/IS pack	ART	Edelstahlilitzendraht 0,014"	Rostfrei 0,012"	Stahl 0,014"
3-1/2	3/4	M14	14000	1 /36	CO90	0178	0946	0172
4-3/4	7/8	M14	12500	1 /32	CO120		2430	0175
5-7/8	1	M14	9000	1 /16	CO150		2433	0176



sitbrush.com

Le dimensioni, le illustrazioni, le caratteristiche tecniche, le referenze e tutti gli altri dati contenuti nel catalogo possono essere modificati da SIT senza preavviso. Tutte le dimensioni riportate sul catalogo sono da considerarsi nominali e, se non diversamente specificato, sono in mm. Diametri, sporgenze e spessori degli insiemi di filamenti, costituenti le spazzole, sono da considerare tali solo approssimativamente.
The dimensions, illustrations, technical characteristics and all other data contained in the catalogue may be changed by SIT without prior notice. All dimensions on the catalogue, unless otherwise specified, are in mm. Diameters, protrusions and thicknesses of sets of filaments forming the brushes are only approximate.

SIT Società Italiana Tecno-spazzole S.p.A

C.F. e Reg. Imprese 03492470376
Via Porrettana, 453
40033 - Casalecchio di Reno (Bo)
ITALY

Partita I.V.A./VAT IT00626581201
Codice SDI: A4707H7
Import/Export BO 008277
R.E.A. BO 295504

Tel. +39 0516113211
Fax +39 051574319
PEC: sit_tecno-spazzole@legalmail.it
info@sitbrush.com

**INDUSTRIAL BRUSHES MANUFACTURER
WITH QUALITY MANAGEMENT SYSTEM
CERTIFIED ISO 9001**

sitbrush.com    