

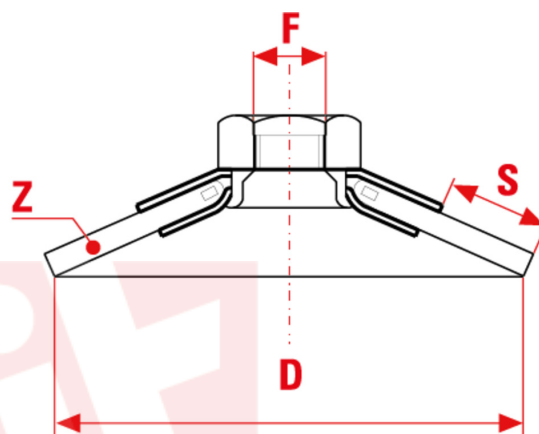

0352



**Z = n° mazzetti / number of knots
n° de mèches torsadées**

Durch die konische Form sind diese Bürsten für Arbeiten „zum Schneiden“ an unregelmäßigen Oberflächen mit Kanten, Profilen und Schlitzen geeignet. Durch die gedrehten Büschel sind diese Bürsten aggressiv.

Die 24-Knoten-Versionen gewährleisten eine bessere Leistung dank einer größeren Bürstenfläche in direktem Kontakt mit der Oberfläche.

ART DER NUTZUNG

Beseitigung von Rückständen, Rost und Ablagerungen von Oberflächen aus beliebigem Material und mit beliebiger Form.

Le dimensioni, le illustrazioni, le caratteristiche tecniche, le referenze e tutti gli altri dati contenuti nel catalogo possono essere modificati da SIT senza preavviso. Tutte le dimensioni riportate sul catalogo sono da considerarsi nominali e, se non diversamente specificato, sono in mm. Diametri, sporgenze e spessori degli insiemi di filamenti, costituenti le spazzole, sono da considerare tali solo approssimativamente.
The dimensions, illustrations, technical characteristics and all other data contained in the catalogue may be changed by SIT without prior notice. All dimensions on the catalogue, unless otherwise specified, are in mm. Diameters, protrusions and thicknesses of sets of filaments forming the brushes are only approximate.

SIT Società Italiana Tecno-spazzole S.p.A

C.F. e Reg. Imprese 03492470376
Via Porrettana, 453
40033 - Casalecchio di Reno (Bo)
ITALY

Partita I.V.A./VAT IT00626581201
Codice SDI: A4707H7
Import/Export BO 008277
R.E.A. BO 295504

Tel. +39 0516113211
Fax +39 051574319
PEC: sit_tecno-spazzole@legalmail.it
info@sitbrush.com

INDUSTRIAL BRUSHES MANUFACTURER
WITH QUALITY MANAGEMENT SYSTEM
CERTIFIED ISO 9001

sitbrush.com

MM**INCH**

D mm	115
S mm	25
Z n°	24
Loch mm	M14
Max RPM	12500
CO/IS pach	1 /32
Art.	CZ115
Gewinde	Stahl
Ø Gewinde	0,50mm

D inch	4-1/2
S inch	1
Z n°	1
Loch inch	M14
Max RPM	12500
CO/IS pack	1 /32
Art.	CZ115
Gewinde	Stahl
Ø Gewinde	0,020"



sitbrush.com

Le dimensioni, le illustrazioni, le caratteristiche tecniche, le referenze e tutti gli altri dati contenuti nel catalogo possono essere modificati da SIT senza preavviso. Tutte le dimensioni riportate sul catalogo sono da considerarsi nominali e, se non diversamente specificato, sono in mm. Diametri, sporgenze e spessori degli insiemi di filamenti, costituenti le spazzole, sono da considerare tali solo approssimativamente.
The dimensions, illustrations, technical characteristics and all other data contained in the catalogue may be changed by SIT without prior notice. All dimensions on the catalogue, unless otherwise specified, are in mm. Diameters, protrusions and thicknesses of sets of filaments forming the brushes are only approximate.

SIT Società Italiana Tecno-spazzole S.p.A

C.F. e Reg. Imprese 03492470376
Via Porrettana, 453
40033 - Casalecchio di Reno (Bo)
ITALY

Partita I.V.A./VAT IT00626581201
Codice SDI: A4707H7
Import/Export BO 008277
R.E.A. BO 295504

Tel. +39 0516113211
Fax +39 051574319
PEC: sit_tecnospazzole@legalmail.it
info@sitbrush.com

**INDUSTRIAL BRUSHES MANUFACTURER
WITH QUALITY MANAGEMENT SYSTEM
CERTIFIED ISO 9001**

sitbrush.com    