

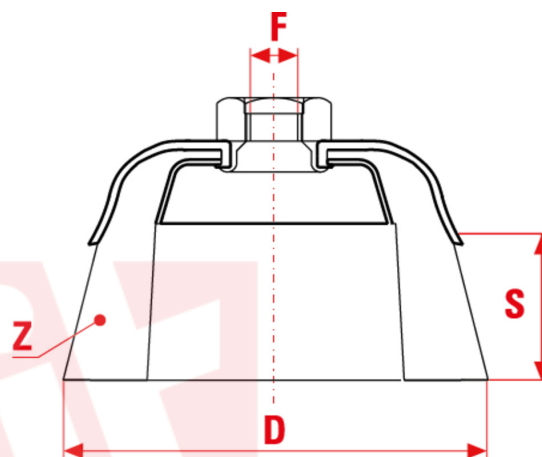

6014



**Z = n° mazzetti / number of knots
n° de mèches torsadées**

X-LOCK ist ein neues 2-teiliges Wechselsystem, um das Zubehör für Winkelschleifer mit nur einem Klick zu wechseln. Ermöglicht das Ver- und Entriegeln der Bürsten von kompatiblen Winkelschleifern bis zu 5 Mal schneller als das klassische System unter absolut sicheren Bedingungen. Eine Weltneuheit von Bosch Professional.

ART DER NUTZUNG

Beseitigung von Rückständen, Rost, Lacken und starken Verkrustungen von Oberflächen beliebiger Art und aus beliebigem Material.

	MM
D mm	70
S mm	17
Z n°	18
Loch mm	X-LOCK
Max RPM	12500
CO/IS pach	1 /18
Art.	TU71 XLK
Gewinde	Stahl
Ø Gewinde	0,50mm

	INCH
D inch	3-3/4
S inch	5/8
Z n°	5/8
Loch inch	X-LOCK
Max RPM	12500
CO/IS pack	1 /18
Art.	TU71 XLK
Gewinde	Stahl
Ø Gewinde	0,020"

Le dimensioni, le illustrazioni, le caratteristiche tecniche, le referenze e tutti gli altri dati contenuti nel catalogo possono essere modificati da SIT senza preavviso. Tutte le dimensioni riportate sul catalogo sono da considerarsi nominali e, se non diversamente specificato, sono in mm. Diametri, sporgenze e spessori degli insiemi di filamenti, costituenti le spazzole, sono da considerare tali solo approssimativamente.
The dimensions, illustrations, technical characteristics and all other data contained in the catalogue may be changed by SIT without prior notice. All dimensions on the catalogue, unless otherwise specified, are in mm. Diameters, protrusions and thicknesses of sets of filaments forming the brushes are only approximate.

SIT Società Italiana TecnoSpazzole S.p.A

C.F. e Reg. Imprese 03492470376
Via Porrettana, 453
40033 - Casalecchio di Reno (Bo)
ITALY

Partita I.V.A./VAT IT00626581201
Codice SDI: A4707H7
Import/Export BO 008277
R.E.A. BO 295504

Tel. +39 0516113211
Fax +39 051574319
PEC: sit_tecnoSpazzole@legalmail.it
info@sitbrush.com

INDUSTRIAL BRUSHES MANUFACTURER
WITH QUALITY MANAGEMENT SYSTEM
CERTIFIED ISO 9001

sitbrush.com